

Quick Installation and Maintenance Instructions

Patient Monitor Mounting



SL-UVDM3-ADA

Medical Facility Responsibility

Preventative maintenance checks must be performed regularly to maintain the quality and performance of this product. Any parts that may be broken, missing, worn, distorted or contaminated in any way should not be used and all affected parts should be replaced immediately. Should the necessity of any repair be suspected; please contact your local Amico distributor.

WARNING: It is the responsibility of the end user to ensure all aspects of installation are covered by following the full manual found on: <http://www.amico.com/plates-and-peripherals>

Installation Tools

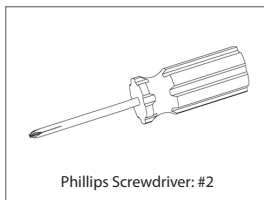

Installation Reference

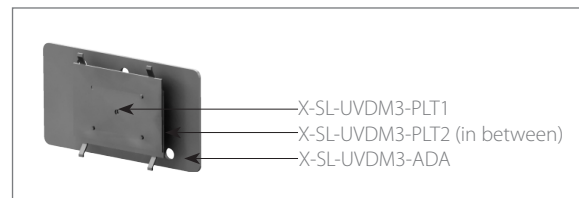

Installation to Mounting Platform

WARNING: Ensure the respective platform is secured safely before installing device.

INSTRUCTIONS:

1. Pull out *PLUNGER PIN* and rotate 90 degrees to lock the pin in the OUT position.
2. With monitor attached, align *ADAPTOR PLATE* to the slot of *PATIENT MONITOR SHELF* and slide it in as shown in **(Figure 1)**.
3. Once *ADAPTOR PLATE* is inserted, rotate 90 degrees to release *PLUNGER PIN* and align with the hole in *ADAPTOR PLATE* as shown in **(Figure 2)**.

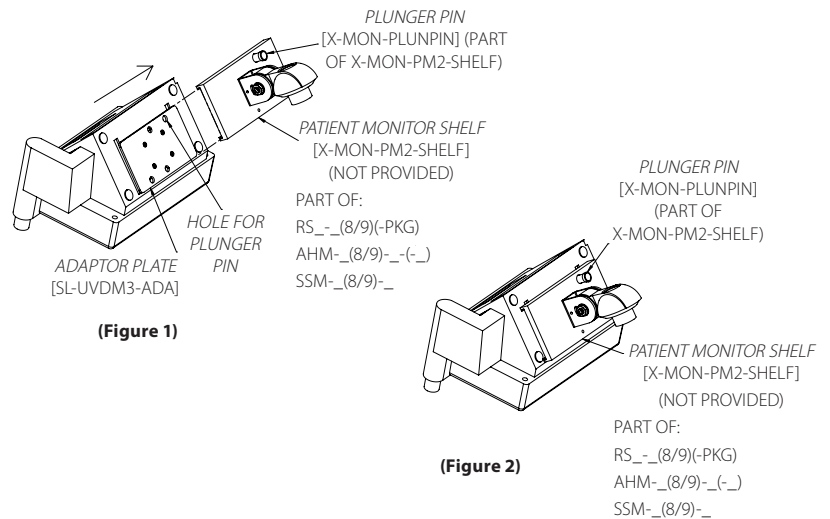

Installation to Device

INSTRUCTIONS:

1. With the flat surface of *PLATE 1* facing away from the monitor, align and insert the two (2) tabs to the bottom two (2) slots of the monitor and rotate it towards the monitor as shown in **(Figure 1)**.
2. With the flat surface of *PLATE 2* facing towards the monitor, align and insert the two (2) tabs to the two (2) top slots of the monitor as shown in **(Figure 2)**.
3. Flatten *PLATE 2* and tighten it with *PANHEAD SCREW* in the middle hole as shown in **(Figure 3)**.
4. Align 4 holes of *ADAPTOR PLATE* or *PLATE 2* and tighten with four (4) *FLATHEAD SCREW* as shown in **(Figure 4)**.

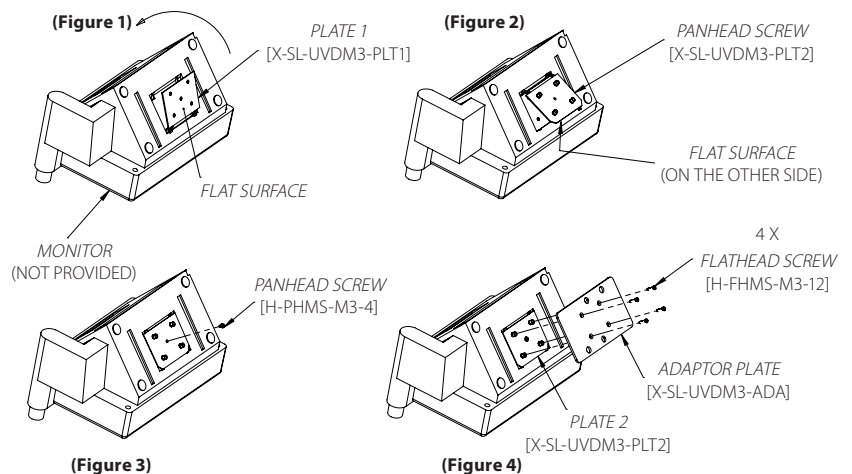

Quick Installation and Maintenance Instructions

Patient Monitor Mounting



SL-UVDM3-ADA

Preventative Maintenance

- ⚠ WARNING:** All products require periodic inspection and maintenance to perform optimally and achieve maximum operation life.
- ⚠ WARNING:** The intervals shown below are recommended. Maintenance schedules should be more frequent for products that see heavy use.
- ℹ NOTE:** Please follow the Preventative Maintenance protocol for the accessories as stated in the manual for those accessories.

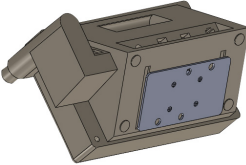
Area	Maintenance	Period (Months)
	<p>AREA 1: Plates and Monitor</p> <ol style="list-style-type: none"> A. Visually inspect for any loosening of the screws from the plate. Check if the device is mounted properly and tightly to the plates. Tighten screws every three months. 	Three (3)

Cleaning

- ⚠ WARNING:** The cleaning chemicals and methods below are not meant for controlling any infections. It shall be the responsibility of the hospital or the hospital's infection control officer to sanitize the equipment.
- ⚠ WARNING:** Please do not spray any chemical directly onto the product. Apply onto a soft cloth and wipe clean to prevent chemicals getting into the product.

The mounting assembly may be cleaned with most mild, non-abrasive solutions commonly used in the hospital environment (e.g. diluted bleach, ammonia, or alcohol solutions). The surface finish will be permanently damaged by strong chemical and solvent such as acetone and trichloroethylene. Steel wool or other abrasive material should never be used. Damaged caused by the use of unapproved substances or processes will not be warranted. It is recommended that you test any cleaning solution on a small area of the product that is not visible to verify compatibility. Never submerge the product and do not allow liquids to enter it. Wipe any cleaning agents off the product immediately using a water-dampened cloth. Dry the product thoroughly after.



No Acetone
Acetone is a colorless, mobile, flammable liquid



No Trichloroethylene
Trichloroethylene is a chlorinated hydrocarbon commonly used as an individual solvent

Troubleshooting Guide

Symptom	Possible Cause	Solution
Monitor on device is loose	Screws have loosened	Tighten screws. If problem persists, please contact Amico Accessories.
Device cannot be tightened into monitor	PLATE 1 and PLATE 2 are not slotted into the monitor correctly*	Remove and reassemble to ensure proper attachment. If problem persists, please contact Amico Accessories.

* Please refer to Parts Legend in Section 2 of the Full Manual (Installation Preparation)

Maintenance

It is recommended that once every three (3) months, all locks, bolts and screws are visually inspected for signs of product wear and tear or damage.

Warranty

During the term of warranty: Within the first twelve (12) months from the date of shipment, Amico Accessories will repair or replace any part which is proven to be defective at no cost. After the twelve (12) month period, Amico Accessories will send the parts to the customer free of charge, however shipping and installation will be borne by the customer.

The warranty is valid only when the product has been properly installed according to Amico Accessories specifications, used in a normal manner, and serviced according to factory recommendations. It does not cover failures due to damage which occur in shipments or failures which resulted from accidents, misuse, abuse, neglect, mishandling, alteration, misapplication or damage that may be attributable to Force Majeure.

AMICO ACCESSORIES DOES NOT HONOR VERBAL STATEMENTS CONCERNING THE WARRANTY.

The distributor and/or dealer are not sanctioned to create verbal warranties about the product described in this agreement. Any statements will not be honored or be made part of the agreement of sale. This document is the final complete and exclusive terms of the agreement.

THIS WARRANTY IS INCLUSIVE AND REPLACES ALL OTHER WARRANTIES.

Amico Accessories shall not, under any circumstances be liable for incidental or consequential damages including, but not limited to, profit, loss of sales or injuries to person(s) or property.

Correction of non-compliance as noted above will result in completion of all liabilities of Amico Accessories whether based on agreement, neglect or changed materials, designs or specifications without notice.

All claims for warranty must first be approved by Amico Accessories Customer Service Department: (info@amico-accessories.com or 1-877-264-2697). A valid Return Goods Authorization number must be obtained from Amico Accessories prior to commencement of any warranty claim.

Amico Accessories Inc. 85 Fulton Way, Richmond Hill, ON L4B 2N4, Canada
Toll Free Tel: 1.877.264.2697 | Tel: 905.763.7778 | Fax: 905.763.8587